

Clima+ 1000

Climate concept for poultry

Post heating unit

The Clima+ concept can be extended with a post heating unit to get even better results during the colder periods. Conditioned air from the heat exchanger is brought to the desired temperature with the integrated heater. This concept allows you to use the Clima+ 1000 all year round. Thereby you can optimally control the temperature in the house which results in better bird performance.

- Optimal environment for birds and humans
- Improved bird performance
- Usage of the heat exchanger all year round
- Easy access for cleaning

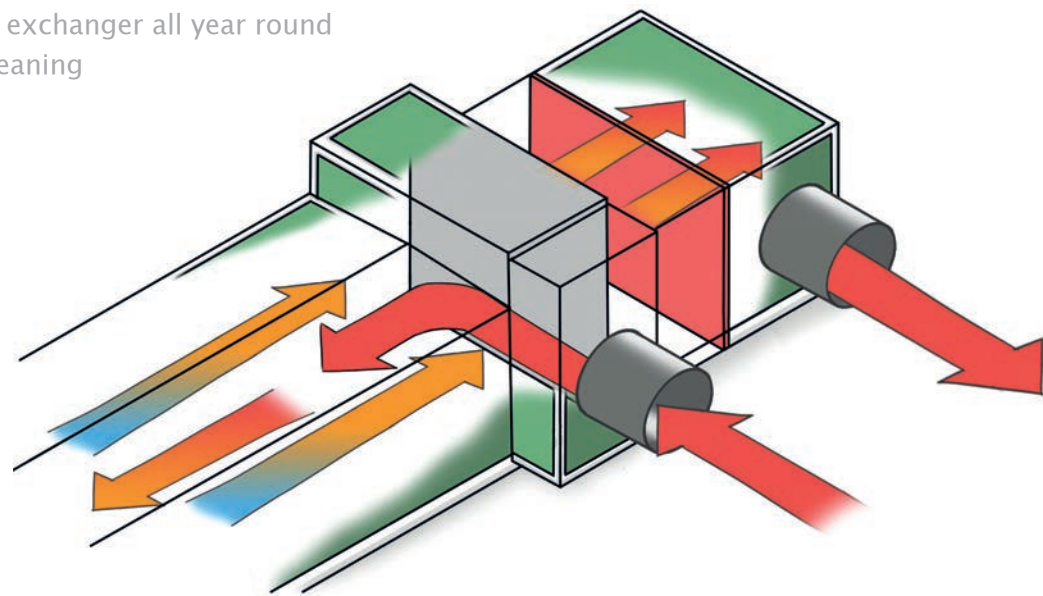

Configurations						
Type	1.0	1.5	2.0	2.5	3.0	3.5
Capacity (m ³ /h)	7,830	11,390	15,310	18,510	22,430	25,990

© 2013 All rights reserved by Agro Supply

Clima+ 1000

Climate concept for poultry



The Netherlands

Clima+ 1000 is part of the Clima+ concept that allows you to fully control the climate in your poultry house. To achieve this we use the Clima+ 1000 heat exchanger to heat up fresh air from outside with warm air taken from inside the house. Thanks to the counter flow air stream it achieves a thermal efficiency of 80%. The preheated air is distributed directly onto the manure belt. This optimizes drying of manure and decreases the humidity resulting in low ammonia emissions. Intelligent software governs this technology and is developed based on a thorough understanding of climate control in poultry houses. With the Clima+ concept you create a perfect and constant climate in the house resulting in optimal bird performances.



Effective manure drying

- Thermal efficiency of 80%
- Manure dry matter content up to 70%
- Significant reduction in fine dust emission

Perfect climate on bird level

- Assuring minimum ventilation at bird level
- Optimal bird performance
- Optimal results through intelligent software
- Direct manure drying resulting in low ammonia levels



Smart design for optimal cleaning

- Integrated automatic cleaning system
- Easy access for thorough cleaning
- Stainless steel parts ensure durability
- Windbreak mesh for pre filtering fresh air

Effective manure drying

- Thermal efficiency of 80%
- Manure dry matter content up to 70%
- Significant reduction in fine dust emission

Perfect climate on bird level

- Assuring minimum ventilation at bird level
- Optimal bird performance
- Optimal results through intelligent software
- Direct manure drying resulting in low ammonia levels

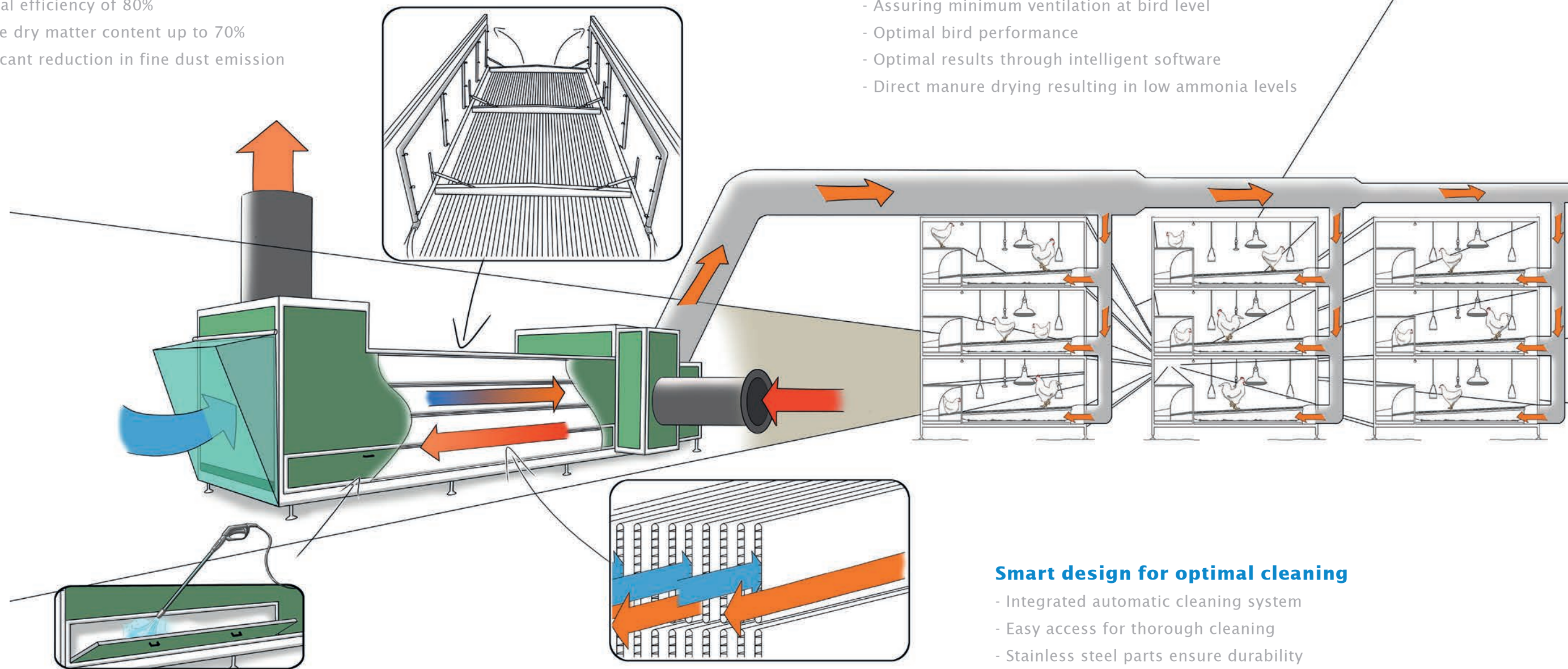

Smart design for optimal cleaning

- Integrated automatic cleaning system
- Easy access for thorough cleaning
- Stainless steel parts ensure durability
- Windbreak mesh for pre filtering fresh air
- Polyester interior panels